

Series P200A-3100/5100

Triplex Ceramic
Plunger Pump
Operating Instructions/
Repair and Service
Manual



Stainless Steel Shown

GIANT

Contents:

Installation Instructions:	page 2
Pump Specifications:	pages 3-7
Parts List / Kits:	page 8
Torque Specifications:	page 8
Exploded View:	page 9
Repair Instructions:	page 10-11
Warranty Information:	back page

Updated 3/98

INSTALLATION INSTRUCTIONS

Installation of the Giant Industries, Inc., pump is not a complicated procedure, but there are some basic steps common to all pumps. The following information is to be considered as a general outline for installation. If you have unique requirements, please contact Giant Industries, Inc. or your local distributor for assistance.

1. The pump should be installed flat on a base to a maximum of a 15 degree angle of inclination to ensure optimum lubrication.
2. The inlet to the pump should be sized for the flow rate of the pump with no unnecessary restrictions that can cause cavitation. Teflon tape should be used to seal all joints. If pumps are to be operated at temperatures in excess of 120° F, it is important to insure a positive head to the pump to prevent cavitation.
3. The discharge plumbing from the pump should be properly sized to the flow rate to prevent line pressure loss to the work area. It is essential to provide a safety bypass valve between the pump and the work area to protect the pump from pressure spikes in the event of a blockage or the use of a shut-off gun.

4. Use of a dampener is necessary to minimize pulsation at drive elements, plumbing, connections, and other system areas. The use of a dampener with Giant Industries, Inc. pumps is optional, although recommended by Giant Industries, Inc. to further reduce system pulsation. Dampeners can also reduce the severity of pressure spikes that occur in systems using a shut-off gun. A dampener must be positioned downstream from the unloader.

5. Crankshaft rotation on Giant Industries, Inc. pumps should be made in the direction designated by the arrows on the pump crankcase. Reverse rotation may be safely achieved by following a few guidelines available upon request from Giant Industries, Inc. Required horsepower for system operation can be obtained from the charts on pages 3-7.

6. Before beginning operation of your pumping system, remember: Check that the crankcase and seal areas have been properly lubricated per recommended schedules. Do not run the pump dry for extended periods of time. Cavitation will result in severe damage. Always remember to check that all plumbing valves are open and that pumped media can flow freely to the inlet of the pump.

Finally, remember that high pressure operation in a pump system has many advantages. But, if it is used carelessly and without regard to its potential hazard, it can cause serious injury.

IMPORTANT OPERATING CONDITIONS

Failure to comply with any of these conditions invalidates the warranty.

1. Prior to initial operation, add oil to the crankcase so that oil level is between the two lines on the oil dipstick. **DO NOT OVERFILL.**

For P218A, P219A and P220A, use Giant Industries, Inc. oil (part # 01060) or the equivalent Kendall Turbo GT1 (20w-50) oil may be used. For P217A use Giant Oil (part #01150) or Mobil 1 (15W-50).

Crankcase oil should be changed after the first 50 hours of operation, then at regular intervals of 500 hours or less depending on operating conditions.

2. Pump operation must not exceed rated pressure, volume, or RPM. A pressure relief device must be installed in the discharge of the system.

3. Acids, alkalines, or abrasive fluids cannot be pumped unless approval in writing is obtained before operation from Giant Industries, Inc.

4. Run the pump dry approximately 10 seconds to drain the water before exposure to freezing temperatures.

Specifications

Model P217A-3100/5100

Volume	Up to 3.4 GPM
Discharge Pressure	Up to 2000 PSI
Inlet Pressure	Up to 90 PSI
RPM	Up to 3450 RPM
Plunger Diameter	18mm
Stroke	5.5mm
Temperature of Pumped Fluids	Up to 160° F
Inlet Ports	(2) 3/8" BSP
Discharge Ports	(2) 3/8" BSP
Shaft Rotation	Top of Pulley Towards Fluid End
Crankshaft Diameter	24mm
Key Width	8mm
Shaft Mounting	Right Side Facing Manifold
Weight	11 lbs. 11oz.
Crankcase Oil Capacity	6.5 fl.oz.
Volumetric Efficiency @ 1750 RPM	0.90
Mechanical Efficiency @ 1750 RPM	0.88

Consult the factory for special requirements that must be met if the pump is to operate beyond one or more of the limits specified above.

NOTE:

In order to drive the pump from the side opposite the present shaft extension, simply remove the valve casing from the crankcase and rotate the pumps 180 degrees to the desired position. Be certain to rotate the seal case (item #20) as well, so that the weep holes are down at the six o'clock position. Exchange the oil fill and the oil drain plugs, also. Refer to the repair instructions as necessary for the proper assembly sequence.

P217A-3100/5100 HORSEPOWER REQUIREMENTS						
RPM	GPM	800 PSI	1200 PSI	1500 PSI	1700 PSI	2000 PSI
1725	1.7	0.9	1.4	1.7	2.0	2.3
3000	3.0	1.7	2.5	3.1	3.5	4.1
3200	3.2	1.8	2.6	3.3	3.8	4.4
3450	3.4	1.9	2.8	3.5	4.0	4.7

HORSEPOWER RATINGS:

The rating shown are the power requirements for the pump. Gas engine power outputs be approximately twice the pump power requirements shown above.

We recommend a 1.15 service factor be specified when selecting an electric motor as the power source. To compute specific pump horse power requirements, use the following formula:

$$HP = (GPM \times PSI) / 1450$$

SPECIAL NOTE:
 The theoretical gallons per revolution (gal/rev) is 0.0009855.
 To find specific outputs at various RPM, use the formula: GPM = 0.0009855 x RPM

Specifications

Model P218A-3100/5100

Volume	Up to 3.4 GPM
Discharge Pressure	Up to 2000 PSI
Inlet Pressure	Up to 90 PSI
RPM	Up to 1750 RPM
Plunger Diameter	18mm
Stroke	10.0mm
Temperature of Pumped Fluids	Up to 160°F
Inlet Ports	(2) 3/8" BSP
Discharge Ports	(2) 3/8" BSP
Shaft Rotation	Top of Pulley Towards Fluid End
Crankshaft Diameter	24mm
Key Width	8mm
Shaft Mounting	Right Side Facing Manifold
Weight	11 lbs. 11oz.
Crankcase Oil Capacity	9.5 fl.oz.
Volumetric Efficiency @ 1750 RPM	0.96
Mechanical Efficiency @ 1750 RPM	0.85

Consult the factory for special requirements that must be met if the pump is to operate beyond one or more of the limits specified above.

NOTE:

In order to drive the pump from the side opposite the present shaft extension, simply remove the valve casing from the crankcase and rotate the pumps 180 degrees to the desired position. Be certain to rotate the seal case (item #20) as well, so that the weep holes are down at the six o'clock position. Exchange the oil fill and the oil drain plugs, also. Refer to the repair instructions as necessary for the proper assembly sequence.

P218A-3100/5100 HORSEPOWER REQUIREMENTS						
RPM	GPM	800 PSI	1200 PSI	1500 PSI	1700 PSI	2000 PSI
1150	2.1	1.2	1.7	2.2	2.5	2.9
1450	2.6	1.5	2.2	2.7	3.1	3.6
1750	3.4	1.9	2.8	3.5	4.0	4.7

HORSEPOWER RATINGS:

The rating shown are the power requirements for the pump. Gas engine power outputs must be approximately twice the pump power requirements shown above.

We recommend a 1.15 service factor be specified when selecting an electric motor as the power source. To compute specific pump horse power requirements, use the following formula:

$$HP = (GPM \times PSI) / 1450$$

SPECIAL NOTE:
 The theoretical gallons per revolution (gal/rev) is 0.00193.
 To find specific outputs at various RPM, use the formula: GPM = 0.00193 x

RPM

Specifications

Model P219A-3100/5100

Volume	Up to 4.2 GPM
Discharge Pressure	Up to 2000 PSI
Inlet Pressure	Up to 90 PSI
RPM	Up to 1750 RPM
Plunger Diameter	18mm
Stroke	12.4mm
Temperature of Pumped Fluids	Up to 160°F
Inlet Ports	(2) 3/8" BSP
Discharge Ports	(2) 3/8" BSP
Shaft Rotation	Top of Pulley Towards Fluid End
Crankshaft Diameter	24mm
Key Width	8mm
Shaft Mounting	Right Side of Manifold
Weight	11 lbs. 11oz.
Crankcase Oil Capacity	9.5 fl.oz.
Volumetric Efficiency @ 1750 RPM	0.96
Mechanical Efficiency @ 1750 RPM	0.85

Consult the factory for special requirements that must be met if the pump is to operate beyond one or more of the limits specified above.

NOTE:

In order to drive the pump from the side opposite the present shaft extension, simply remove the valve casing from the crankcase and rotate the pumps 180 degrees to the desired position. Be certain to rotate the seal case (item #20) as well, so that the weep holes are down at the six o'clock position. Exchange the oil fill and the oil drain plugs, also. Refer to the repair instructions as necessary for the proper assembly sequence.

P219A-3100/5100 HORSEPOWER REQUIREMENTS				
RPM	GPM	1000 PSI	1500 PSI	2000 PSI
1150	2.7	1.9	2.8	3.7
1450	3.5	2.4	3.6	4.8
1750	4.2	2.9	4.3	5.8

HORSEPOWER RATINGS:

The rating shown are the power requirements for the pump. Gas engine power outputs must be approximately twice the pump power requirements shown above.

We recommend a 1.15 service factor be specified when selecting an electric motor as the power source. To compute specific pump horse power requirements, use the following formula:

$$HP = (GPM \times PSI) / 1450$$

SPECIAL NOTE:
 The theoretical gallons per revolution (gal/rev) is 0.00239.
 To find specific outputs at various RPM, use the formula: $GPM = 0.00239 \times$

RPM

Specifications

Model P220A-3100/5100

Volume	Up to 4.7GPM
Discharge Pressure	Up to 2000 PSI
Inlet Pressure	Up to 90 PSI
RPM	Up to 1725 RPM
Plunger Diameter	18mm
Stroke	14.1mm
Temperature of Pumped Fluids	Up to 160°F
Inlet Ports	(2) 3/8" BSP
Discharge Ports	(2) 3/8" BSP
Shaft Rotation	Top of Pulley Towards Fluid End
Crankshaft Diameter	24mm
Key Width	8mm
Shaft Mounting	Right Side Facing Manifold
Weight	11 lbs. 11oz.
Crankcase Oil Capacity	9.5 fl.oz.
Volumetric Efficiency @ 1750 RPM	0.945
Mechanical Efficiency @ 1750 RPM	0.86

Consult the factory for special requirements that must be met if the pump is to operate beyond one or more of the limits specified above.

NOTE:

In order to drive the pump from the side opposite the present shaft extension, simply remove the valve casing from the crankcase and rotate the pumps 180 degrees to the desired position. Be certain to rotate the seal case (item #20) as well, so that the weep holes are down at the six o'clock position. Exchange the oil fill and the oil drain plugs, also. Refer to the repair instructions as necessary for the proper assembly sequence.

P220A-3100/5100 HORSEPOWER REQUIREMENTS						
RPM	GPM	800 PSI	1200 PSI	1500 PSI	1700 PSI	2000 PSI
1150	3.1	1.7	2.5	3.2	3.6	4.2
1450	3.9	2.1	3.2	4.0	4.6	5.4
1750	4.7	2.6	3.9	4.9	5.5	6.5

HORSEPOWER RATINGS:

The rating shown are the power requirements for the pump. Gas engine power outputs must be approximately twice the pump power requirements shown above.

We recommend a 1.15 service factor be specified when selecting an electric motor as the power source. To compute specific pump horse power requirements, use the following formula:

$$HP = (GPM \times PSI) / 1450$$

SPECIAL NOTE:
 The theoretical gallons per revolution (gal/rev) is 0.00266.
 To find specific outputs at various RPM, use the formula: GPM = 0.00266 x
 RPM

Specifications

Model P221A-3100

Volume	Up to 2.3GPM
Discharge Pressure	Up to 2000 PSI
Inlet Pressure	Up to 90 PSI
RPM	Up to 1750 RPM
Plunger Diameter	18mm
Stroke	14.1mm
Temperature of Pumped Fluids	Up to 160°F
Inlet Ports	(2) 3/8" BSP
Discharge Ports	(2) 3/8" BSP
Shaft Rotation	Top of Pulley Towards Fluid End
Crankshaft Diameter	24mm
Key Width	8mm
Shaft Mounting	Right Side Facing Manifold
Weight	11 lbs. 11oz.
Crankcase Oil Capacity	9.5 fl.oz.
Volumetric Efficiency @ 1750 RPM	0.90
Mechanical Efficiency @ 1750 RPM	0.88

Consult the factory for special requirements that must be met if the pump is to operate beyond one or more of the limits specified above.

NOTE:

In order to drive the pump from the side opposite the present shaft extension, simply remove the valve casing from the crankcase and rotate the pumps 180 degrees to the desired position. Be certain to rotate the seal case (item #20) as well, so that the weep holes are down at the six o'clock position. Exchange the oil fill and the oil drain plugs, also. Refer to the repair instructions as necessary for the proper assembly sequence.

P221A-3100 HORSEPOWER REQUIREMENTS						
RPM	GPM	800 PSI	1200 PSI	1500 PSI	1700 PSI	2000 PSI
1150	1.5	0.8	1.2	1.6	1.8	2.1
1450	1.9	1.0	1.6	2.0	2.2	2.6
1750	2.3	1.3	1.9	2.4	2.7	3.2

HORSEPOWER RATINGS:

The rating shown are the power requirements for the pump. Gas engine power outputs must be approximately twice the pump power requirements shown above.

We recommend a 1.15 service factor be specified when selecting an electric motor as the power source. To compute specific pump horse power requirements, use the following formula:

$$HP = (GPM \times PSI) / 1450$$

SPECIAL NOTE:

The theoretical gallons per revolution (gal/rev) is 0.00131.
To find specific outputs at various RPM, use the formula: GPM = 0.00131 x RPM

P200A-3100/5100 SERIES PARTS LIST

ITEM	PART NO.	DESCRIPTION	QTY.	ITEM	PART NO.	DESCRIPTION	QTY.
1	08300	Crankcase	1	17	08442	Wrist Pin	3
2	08301	Oil Fill Plug with Gasket (P217-5100 & P221A-3100)	1	18	07770	O-Ring (P221-3100)	3
2	08480	Dipstick		19	08356-0010	Oil Seal	3
3	08302	Crankcase Plug Cover	1	20	08444-0100	Seal Case	3
3A	07190	Drain Plug & Gasket	1	20	12259-0300	Seal Retainer (P221-3100)	3
4	08005	O-Ring	1	21	08443	O-Ring	3
5	08185	Oil Drain Plug	1	21	12260-0300	O-Ring (P221-3100)	3
6	07188-0100	Screw, 316 S.S.	4	23	08087	V-Sleeve	6
6A	07223-0100	Spring Washer, 316 S.S.		23	8477	Grooved Seal (P221-3100)	3
7	08303	Bearing Cover I	2	23A	8087	Grooved Seal Ring, Brown (P221-3100)	3
8	08490	Sight Glass	1	24	07904	Pressure Ring	3
9	08492	O-Ring	1	24	12261-0300	Support Ring (P221-3100)	3
10	07225-0100	Screw with Lock Washer	8	25	08445-0100	Weep Return Ring, 316 S.S.	3
10A	07223-0100	Spring Washer	8	26	08446-5000	Valve Casing	1
11	01166	Radial Shaft Seal	1	26	12262-3000	Valve Casing (P221-3100)	1
12A	08020	Ball Bearing	1	27	07849-0100	Valve Seat	6
12B	01020	Ball Bearing	1	28	07491-0100	Valve Plate	6
13	08465	Crankshaft (P217A Series)	1	29	07906	Valve Spring	6
13	08440	Crankshaft (P218A Series)	1	30	07907	Valve Spring Retainer	6
13	08466	Crankshaft (P219A Series)	1	31	07853	O-Ring	6
13	08467	Crankshaft (P220A Series)	1	31	7853-0001	O-Ring	6
13	12258	Crankshaft (P221A-3100)	1	32	07928-0100	Valve Plug	6
14	06207	Woodruff Key	1	32	12263-0300	Plug (P221-3100)	6
15	08333	Connecting Rod	3	33	07913	O-Ring	6
16	08469-0100	Plunger, Complete 18mm	3	33	12264-0300	O-Ring (P221-3100)	6
16A	08468-0100	Plunger Base	3	34	08613-0100	Hex Head Cap Screw	8
16B	08455	Plunger Pipe	3	36	12138	Plug	2
16C	08456-0100	Tension Screw	3	36	12265	Plug (P221-3100)	2
16D	07204-0100	Copper Gasket, 316 S.S.	3				

P200A-3100/5100 SERIES REPAIR KITS

Plunger Packing Kit

Part# 09164

Qty.	Part #	Description
6	08087	V-Sleeve
3	07904	Pressure Ring

Oil Seal Kit

Part# 09144

Qty.	Part #	Description
3	08356-0010	Oil Seal

Plunger Packing Kit

Part # 09460 (P221A-3100)

Qty.	Part #	Description
3	08087	V-Sleeve
3	08477	Grooved Seal
3	07904	Pressure Ring

Valve Assembly Kit

Part # 09211

Qty.	Part #	Description
6	07849-0100	Valve Seat
6	07491-0100	Valve Plate
6	07906	Valve Spring
6	07907	Valve Retainer
6	07853	O-Ring

P200A-3100/5100 SERIES TORQUE SPECIFICATIONS

Position	Item#	Description	Torque Amount (ft.-lbs)
16C	08456	Tension Screw, Plunger	120 (in.-lbs.)
32	07928	Valve Plug	33 (ft.-lbs.)
34	08316	Hex Head Cap Screw, Valve Casing	105 (in.-lbs.)

Exploded View - P200A-3100/5100 Series

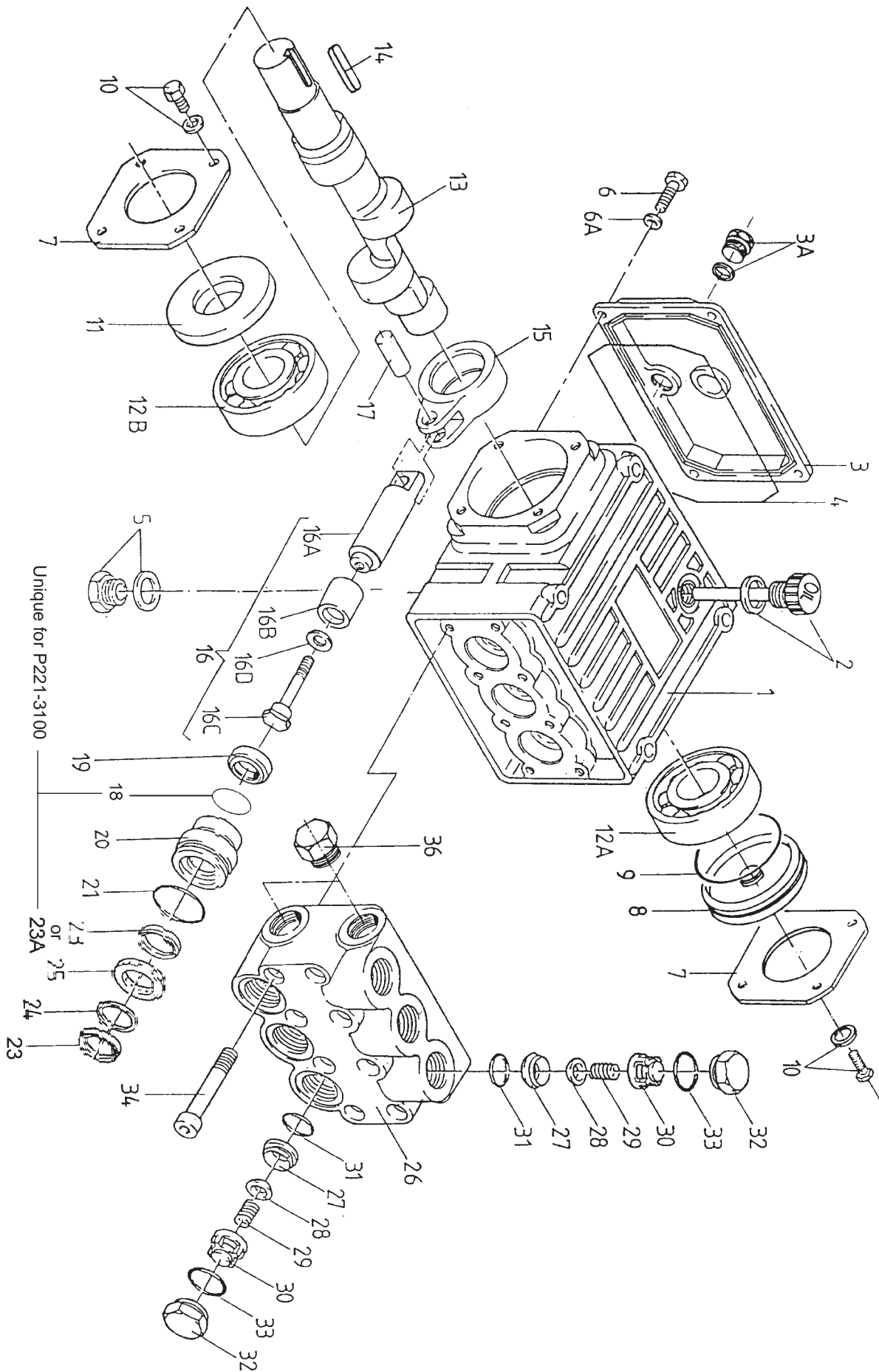

REPAIR INSTRUCTION - P200A-3100/5100 SERIES

Disassembly sequence of fluid end of P200A-3100/5100 series pump

Note: Always take time to lubricate all metal and nonmetal parts with a light film of oil before reassembly. This step will ensure proper fit, at the same time protecting the pump nonmetal parts (i.e., the elastomers) from cutting and scoring.

- 1) With a 22mm socket wrench, remove the (3) discharge valve plugs and (3) inlet valve plugs (32). Inspect the o-ring (33) for wear and replace if damaged.
- 2) Using a needle nose pliers, remove the inlet and discharge valve assemblies (32X). By inserting a small screw driver between the valve seat (27) and the valve spring retainer (30), the valve assembly can be separated. Remove the o-ring (31). Inspect all parts for wear and replace as necessary.
- 3) Next, use a 5mm allen wrench to remove the 8 socket head cap screws (34). Carefully slide the valve casing (26) out over the plungers. Remove the weep return ring (25), pressure ring (24), and v-sleeve (23) from the valve casing (26). Remove the v-sleeve (23) from the seal case (20). Inspect all parts, including o-ring (21) for wear and replace as necessary.
- 4) Check surfaces of plunger (16). A damaged surface will cause accelerated wear on the seals. Deposits of any kind must be carefully removed from the plunger surface. A damaged plunger must be replaced!
- 5) If the ceramic plunger pipe (16B) is damaged, remove the plunger bolt (16C). Discard the old plunger pipe (16B) and copper gasket (16D), and clean the old locktite from the plunger bolt (16C) and plunger base (16A). Replace the plunger with the new one and locktite the plunger bolt and torque to 120 inch-pounds.

Note: If there are deposits of any kind (i.e., lime deposits) in the valve casing, be certain that the weep holes in the weep return ring (25) and valve casing (26) have not been plugged.

- 5) If the crankcase oil seals (19) are to be replaced, they can be removed by prying loose with a flat screwdriver. Take care not to make contact with the plunger. If the oil seals are not to be replaced, proceed to the back end disassembly sequence and carefully pry the seals loose after the plungers have been removed from the crankcase. The seals should not be reinstalled until after step #2 of the "Reassembly Sequence".

REPAIR INSTRUCTION - P200A-3100/5100 SERIES

Disassembly sequence of the *back* end of the P200A-3100/5100 series pump.

- 1) Before you begin, drain the oil from the crankcase.
- 2) Remove the crankcase cover (3) and o-ring (4) from the crankcase (1). To remove the crankshaft (13), remove the bearing cover (7) and sight glass (8). Using a rubber mallet, remove the crankshaft axially through the connecting rods by tapping on the end of the shaft. Be careful not to bend or damage the connecting rods during crankshaft removal.
- 3) If the bearings (12A and 12B) and radial shaft seal (11) are still in the crankcase, remove them. Inspect both bearings and seal for wear and replace if necessary.
- 4) Remove the connecting rod (15) and plunger (16). Remove the wrist pin (17) if necessary. Check the plunger bore in the crankcase for wear. Inspect parts and replace as necessary.
- 5) Should you find it necessary to service the plunger assembly (#16) you can do so by removing the tension screw (#16D). Inspect all parts and replace as necessary.

Reassembly sequence of the of the P200A-3100/5100 series pump

- 1) Reassemble plunger (16) and the connecting rod (15) with wrist pin (17). Place assemblies in crankcase (1). Install crankshaft through connecting rods again being careful not to bend or otherwise damage the connecting rods.
- 2) Replace left and right side bearings (12A and 12B) if they were removed from the crankshaft. Be certain the bearings are pressed all the way onto the shaft and completely into the crankcase. Replace radial shaft seal (11), bearing cover (7), sight glass (8), and crankcase cover (3) with its o-ring (4).
- 3) If oil seals (19) were removed, replace with seal lip towards crankcase. Lubricate seal before replacing.
- 4) Replace seal case (20) with o-rings (21) over plungers. Generously lubricate o-rings and oil seal before reassembly. Replace v-sleeve (23) over plungers (16)..
- 5) Generously lubricate v-sleeve (23). Assemble v-sleeves (22) into valve casing (#26). Assemble weep return ring (25) and pressure ring (24) over plungers (16). Slide valve casing over plungers and seat firmly. Replace the eight socket head cap screws (34) and tighten to 105 inch-pounds in a crossing pattern.
- 6) Replace the six o-rings (31) and the six valve assemblies (32X). Now replace the six valve plugs with o-rings (32 and 33) and tighten securely with a 22mm socket wrench to 33 foot-pounds.
- 7) Fill crankcase with 9.5 ounces (6.5 ounces for P217A) of oil.

NOTE: Contact Giant Industries for Service School Information. Phone: (419)-531-4600

P200A-3100/5100 DIMENSIONS (mm)

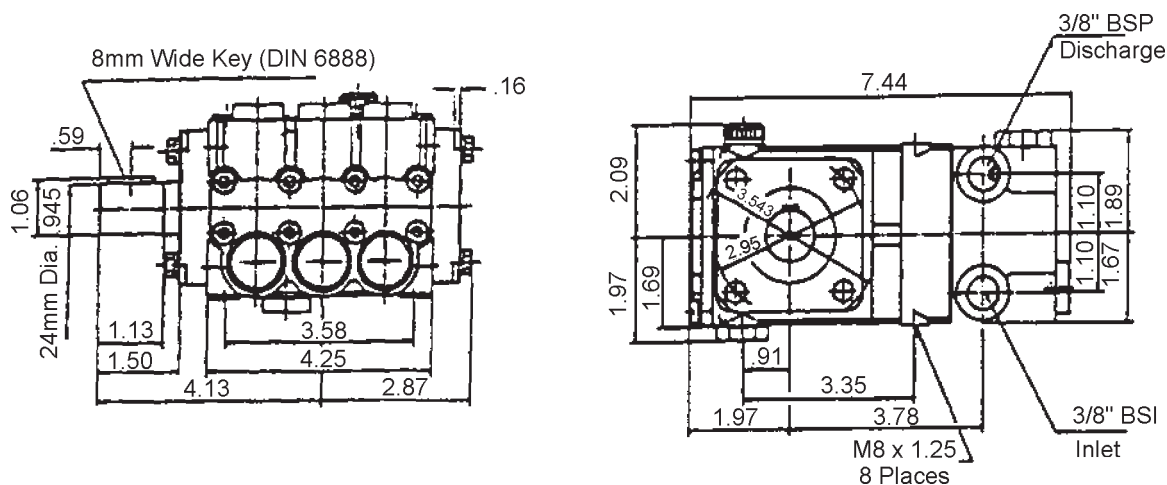

GIANT INDUSTRIES LIMITED WARRANTY

Giant Industries, Inc. pumps and accessories are warranted by the manufacturer to be free from defects in workmanship and material as follows:

1. For portable pressure washers and car wash applications, the discharge manifolds will never fail, period. If they ever fail, we will replace them free of charge. Our other pump parts, used in portable pressure washers and in car wash applications, are warranted for five years from the date of shipment for all pumps used in NON-SALINE, clean water applications.

2. One (1) year from the date of shipment for all other Giant industrial and consumer pumps.
3. Six (6) months from the date of shipment for all rebuilt pumps.
4. Ninety (90) days from the date of shipment for all Giant accessories.

This warranty is limited to repair or replacement of pumps and accessories of which the manufacturer's evaluation shows were defective at the time of shipment by the manufacturer. The following items are NOT covered or will void the warranty:

1. Defects caused by negligence or fault of the buyer or third party.
2. Normal wear and tear to standard wear parts.
3. Use of repair parts other than those manufactured or authorized by Giant.
4. Improper use of the product as a component part.
5. Changes or modifications made by the customer or third party.
6. The operation of pumps and or accessories exceeding the specifications set forth in the Operations Manuals provided by Giant Industries, Inc.

Liability under this warranty is on all non-wear parts and limited to the replacement or repair of those products returned freight prepaid to Giant Industries which are deemed to be defective due to workmanship or failure of material. A Returned Goods Authorization (R.G.A.) number and completed warranty evaluation form is required prior to the return to Giant Industries of all products under warranty consideration. Call (419)-531-4600 or fax (419)-531-6836 to obtain an R.G.A. number.

Repair or replacement of defective products as provided is the sole and exclusive remedy provided hereunder and the MANUFACTURER SHALL NOT BE LIABLE FOR FURTHER LOSS, DAMAGES, OR EXPENSES, INCLUDING INCIDENTAL AND CONSEQUENTIAL DAMAGES DIRECTLY OR INDIRECTLY ARISING FROM THE SALE OR USE OF THIS PRODUCT.

THE LIMITED WARRANTY SET FORTH HEREIN IS IN LIEU OF ALL OTHER WARRANTIES OR REPRESENTATION, EXPRESS OR IMPLIED, INCLUDING WITHOUT LIMITATION ANY WARRANTIES OR MERCHANTABILITY OR FITNESS FOR A PARTICULAR PURPOSE AND ALL SUCH WARRANTIES ARE HEREBY DISCLAIMED AND EXCLUDED BY THE MANUFACTURER.



GIANT INDUSTRIES, INC., 900 N. Westwood Ave., P.O. Box 3187, Toledo, Ohio 43607
PHONE (419) 531-4600, FAX (419) 531-6836, www.giantpumps.com
© Copyright 1998 Giant Industries, Inc.